

Please read instructions carefully to avoid accidental damage to components during assembly.

Quality Wooden Children's Furniture and Accessories
 Made in America • Established 1987
 www.littlecolorado.com

Revised 10/10
 by
 E. Layton

⚠ WARNING: ADULT ASSEMBLY REQUIRED

⚠ WARNING: Assembly kit contains parts with sharp points.

⚠ WARNING: Assembly kit contains parts with sharp edges.

⚠ WARNING: Package contains plastic bags that present suffocation risks for children.

⚠ WARNING: Assembly kit contains small parts that present choking hazards for children.

Treasure Chest Assembly Instructions; Stock # 53

- Please inspect the parts for damage during shipping and for any missing items. If you suspect that there may be damage or a shortage, contact us and we will send replacement parts if needed.
- As soon as components and hardware are unpacked; please remove and recycle all plastic bags from possible contact with children.
- Words in **Red** represent a component or hardware used in assembly.
>
- Illustrations are intended to help identify components and hardware and are not drawn to scale.

Treasure Chest Components

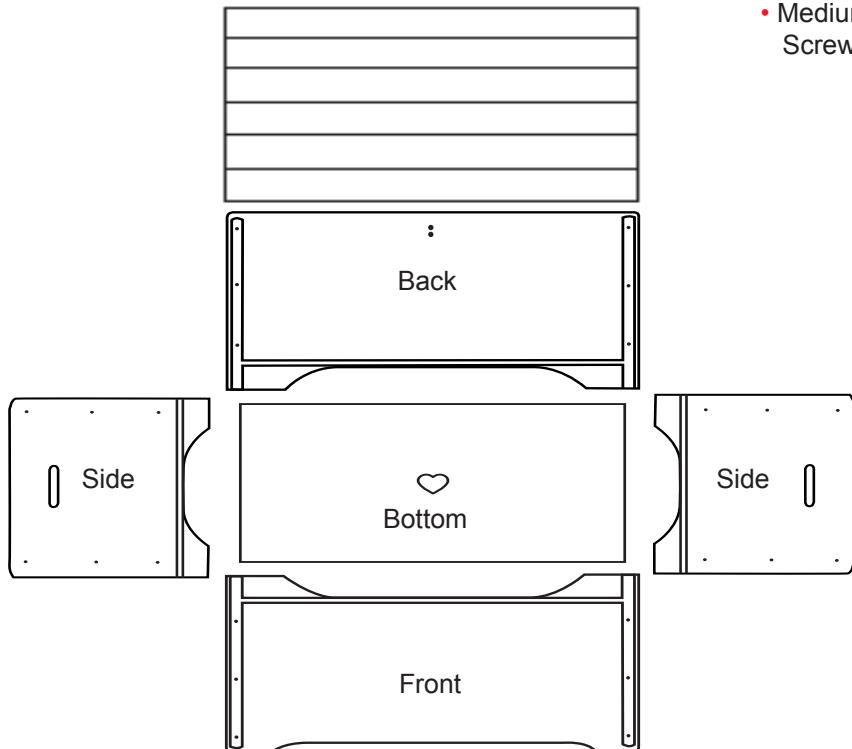

Tools needed for assembly

- Medium size #2 Phillips Screwdriver

Treasure Chest Hardware

1- Lid Support

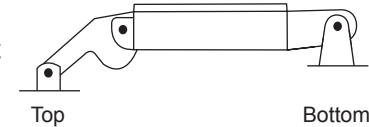

12- Cam Locks

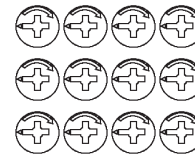

12- Cam Posts

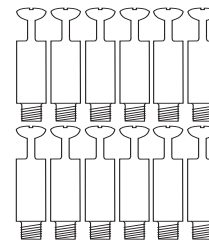

14- #5 5/8 in.
Wood Screws

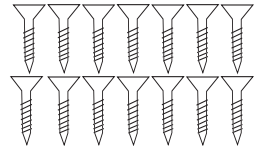

4- #8 5/8 in.
Wood Screws

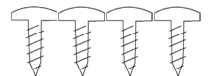

Treasure Chest Assembly Instructions- Continued

1

- Use a #2 Phillips head screwdriver to screw in 3 **Cam Posts** to each side of **Back**.
- Each cam post must be fully seated and perpendicular.

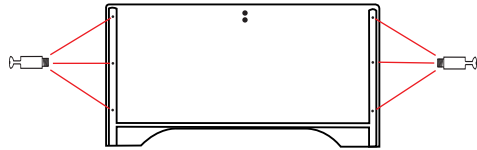

Back Panel

2

- Insert **Cam Posts** in holes on edge of **Side**. This maybe a tight fit. Some minor adjusting and fitting may be needed.

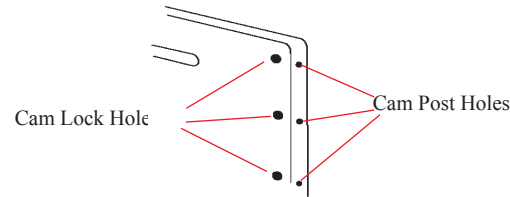

Partial view of Side

3

- Insert 3 **Cam Locks** into the Cam Lock holes on the side component. The arrow head on the face of the Cam needs to be pointing toward the head of the Cam Post.

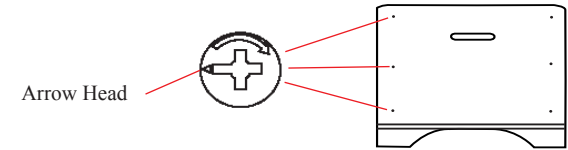

- Turn the Cam 1/2 turn Clockwise until cam stops.
- Now, repeat steps 2 and 3 to assemble the other side.

4

- Now that you have the two sides fastened to the back; slide the **bottom** panel in the bottom grooves (The side with the Little Colorado logo is the top side).

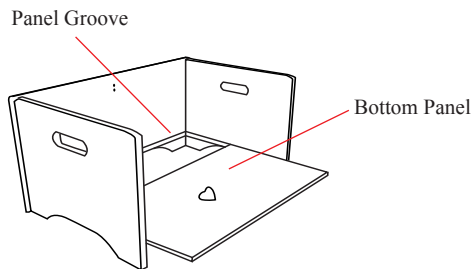

- Repeat steps 1, 2 and 3 to attach **Front** panel to body

5

- Using the existing holes, attach bottom of **Lid Support** to inside of **Back** with 2 **#8 x 5/8"** screws

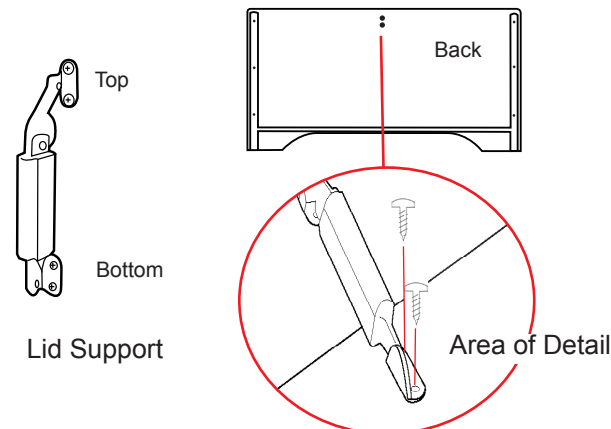

Lid Support

6

- Place **Lid** on top of the box and line up existing holes located on outside of the back panel to holes in hinge. Attach hinge to back of box using 14 **#5 x 5/8"** screws.
- Be careful not to over tighten screws.

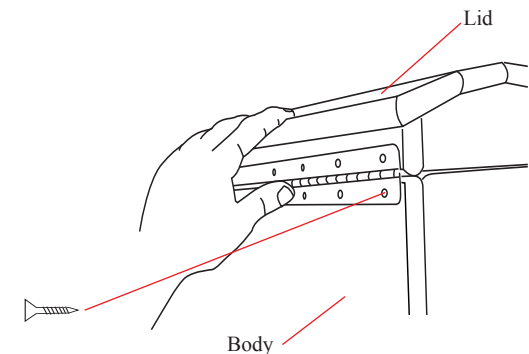

Treasure Chest Assembly Instructions- Continued

7

- Carefully open up lid to 75 degrees and hold it in that position. Then attach the top mounting bracket of the Lid Support to the inside of the lid using the existing holes and 2 #8 screws.
- It is very important that the existing holes line up perfectly or the lid support may not function properly.
- Be careful not to over tighten screws.

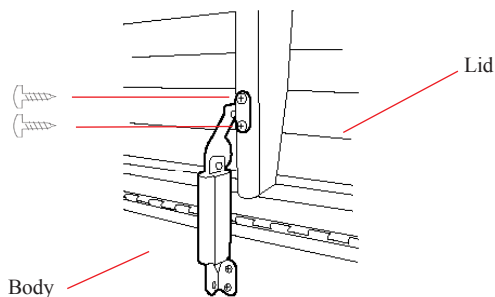

8

- Now that you have completed the assembly, open and close the lid 10 times to break in the lid support mechanism.
- The lid should not fall when the Lid Support is properly installed.
- If the lid does not stay in position when raised, please call us and we will help you. Until the lid support is properly installed, do not allow children to use this product. Please check the mounting screws periodically to be sure they remain tight,

If you would like your Treasure Chest Personalized with your child's name. Contact us at 303 964 3212 and we will take your order and mail you your child's name complete with mounting instructions.

⚠ WARNING
Failure to properly install
the lid support will result in
an entrapment hazard

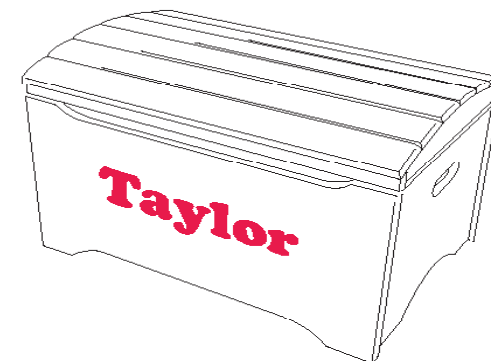

Use and Care Instructions

The finish on this product is an environmentally friendly water base acrylic made by Sherwin Williams. It may be cleaned with a furniture polish, lemon oil or a non abrasive cleaner using a soft cloth. **DO NOT USE AMMONIA** or products containing ammonia such as Windex glass or multi-surface cleaner. Scuff marks can usually be removed by using a polishing compound sold at auto parts stores.

Little Colorado, Inc is a family run children's furniture manufacturer located in Denver. Please check out www.littlecolorado.com to see our other products that are all made here in America. The safety of your children is our highest concern. We are a **GREEN** company and hope you will be able to recycle the packaging material that we used to ship your product.

If you have a comment or a question please contact us at info at info@littlecolorado.com. All of us at Little Colorado hope you and your family will enjoy this product for many years.